

Permanent Infrared Hotspot Detection



- ✓ Proven Technology
- ✓ Specified in projects world wide
- ✓ Adopted globally by OEMs
- ✓ 24x7 Real time status/alarm
- ✓ Increased uptime and reliability
- ✓ Increased Safety
- ✓ Low Load fault detection

The Problem: Detecting electrical failure

The most common cause of electrical failures and arc flash incidents is poor busbar:busbar joints and cable terminations.

A compromised joint can only be identified by the excess heat it generates. Not to confuse 'excess heat' with 'heat rise', Exertherm sensors measure the Delta T (ΔT). Sensors are permanently installed inside energised electrical equipment to directly view and continuously monitor the condition of critical joints.

Exertherm 24x7 monitoring detects hotspots at an early stage of development preventing downtime caused by electrical failure and arc flash incidents.

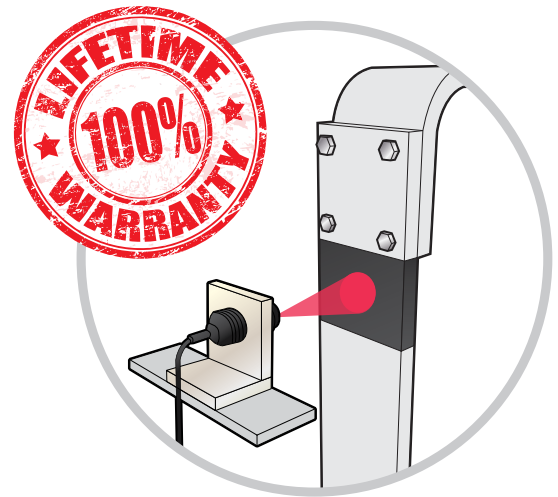

Exertherm non-contact infrared sensor

What are the benefits of permanent Exertherm® IR sensor system over periodic?

	Periodic Thermal Imaging/Windows	Permanent Exertherm® IR Sensor System
Inspection Frequency	Typically 1 day out of 365 = <1% of time	24x7/365 = 100% of time
% Chance of Problem Detection	0.27%	100%
Positioning	External	Internal
View	Limited	Unlimited - direct line of sight
Reliability	Dependent on luck/correlation	Continuous reliable data
Availability	Data is not integrated or real-time	Real-time data - integrated to BMS/EMS/SCADA
Safety	Places operator at risk	Increases facility/operator safety
Self-diagnostics	Operator dependent	Automatic
Low Load	Extremely difficult to detect faults	Load related alarm thresholds

What does Exertherm® Thermal Monitoring provide?

- ✓ Increased operator & facility safety
- ✓ Increased operational uptime
- ✓ Reduced risk of fire/explosion resulting from Arc Flash
- ✓ Real-time data = improved critical asset integrity
- ✓ Reduced unplanned maintenance
- ✓ OEM vendor neutral
- ✓ Suitable for retrofit or new-build
- ✓ Enhanced protection for critical circuits operating at low load

RISK



NO RISK



The Exertherm[®] System: Detecting the Problem

EXERTHERM
by **EATON**

1 Infrared Sensors

Our small, non-contact, plastic IR Sensors have lifetime calibration and require no external power. These are placed within the enclosure to directly monitor key connections through ΔT measurement.

2 Cable Sensors

Our patented cable sensors strap to the cable to monitor cable joints via ΔT measurement.

3 Datacards

Our Datacards facilitate the collection of data from the IR or Cable sensors (8 per data card) and transmit it to the host system via the ModBus protocol. They feature RJ45 sockets for easy integration and connection to your RS485 Modbus network.

4 ARM XL

Simple, easy to use, pre-configured, panel mounted 4.3" touch screen HMI with LoadMap[®] software.

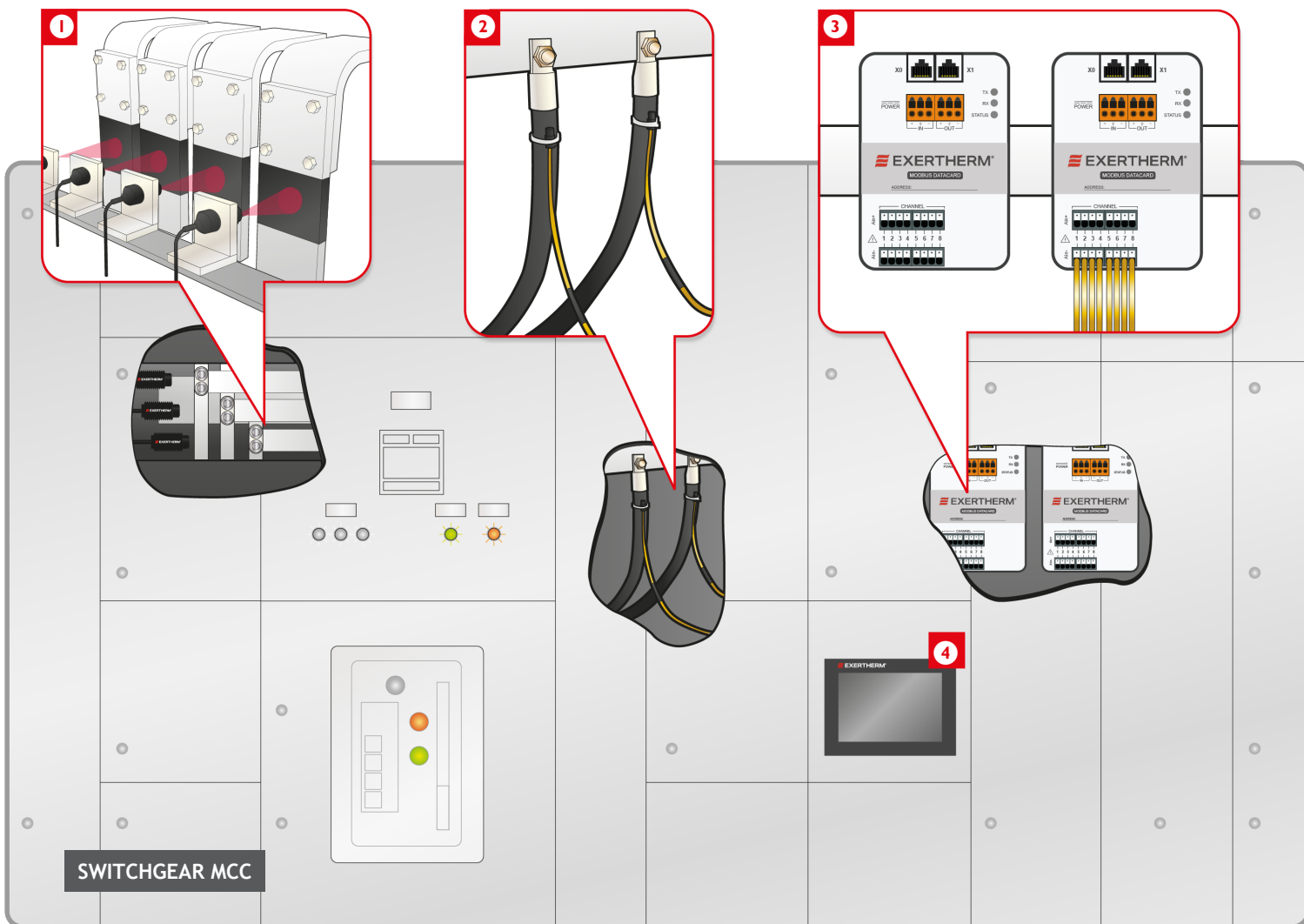

Where to permanently monitor?

The Exertherm solution is suitable for either LV or MV applications, enabling the following critical and key connections (including insulated bus) to be monitored in real-time:

- ✓ All AIS circuit breakers – line/load side
- ✓ Bus couplers – line/load side
- ✓ Critical vertical to horizontal bus connections
- ✓ MCC power IN / OUT connections (see MCC 'in-drawer' solution)
- ✓ Critical cable connections – typically above 400A (via specialist Exertherm Cable sensors)
- ✓ All shipping/transport joints
- ✓ Also suitable for insulated bus'

5 Integration Options

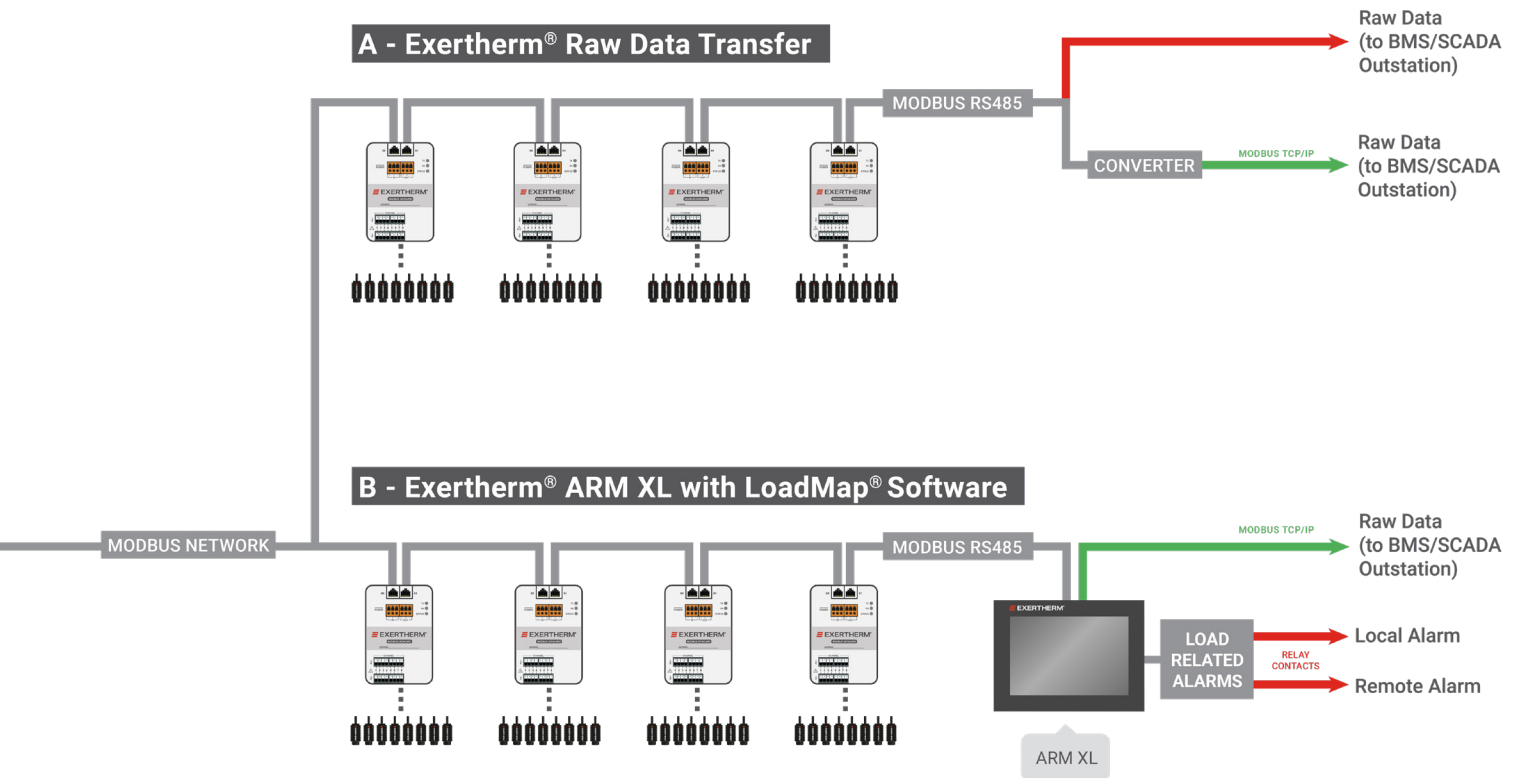

LOADMAP®

Why load related alarms are important

Load is a critical factor in the ability to accurately detect compromised joints/terminations. Early detection of compromised joints operating at low loads by utilising temperature & load data provides an enhanced level of protection for 24x7 operation facilities, which periodic thermal imaging cannot provide.



Provides verification that compromised joints are not present on critical circuits by providing load related alarm thresholds.



Simple, easy to use LoadMap® software calculates the alarm threshold suitable for maximum load on the circuit being monitored, increasing load and capacity planning capability.



Identifies the dynamic condition of joints when under high or overload situations, thus providing enhanced levels of safety, asset integrity, and operational uptime.



Manual entry of maximum anticipated load on circuits provides load based warning alarm level e.g. 100% load = $\Delta 40C$ but 60% load = $\Delta 14.4C$



Condition based monitoring enables periods between scheduled intervention maintenance to be increased. In addition, only joints requiring remedial action need be touched. The result is significant savings in maintenance downtime improved operator/facility safety.



Improved asset integrity management combined with increased equipment life due to improved knowledge.

Alarm Relay Module XL (ARM XL)



Product Overview

The Exertherm Alarm Relay Module XL (ARM XL) device is ideal for those who wish to continuously thermally monitor critical electrical circuits, 100% of operational time, rather than rely on one day per year thermal inspections. It is designed for busy engineers who require a simple monitoring system to just inform when and where a fault is detected, without yet another suite of software.

The Exertherm ARM XL device is designed to provide a complete integral monitoring solution per switchboard, and is suitable for both new build or retro-fit, while being entirely vendor neutral (e.g. can be fitted to any manufacturer's equipment).

The key benefits of the ARM XL:

- Monitoring 24x7 up to 80 Exertherm Sensors and / or up to 60 MCC Drawers for potentially compromised joints and terminations;
- Using industry standard Modbus TCP/IP allows the pass through of the 'raw temperature data' to a host system – this enables data to be integrated, trended and stored according to client requirements;
- Protecting circuits operating at a low load with the Patented Exertherm LoadMap solution. This can adjust the warning alarm level to suit the maximum load that will be applied to a circuit being thermally monitored. (This is only applicable to the circuits using the 8ch Datacard / IR EM Sensors).

This simple to use, plug and play device, which has 2 sets dry contact relays for connection to a local alarm output and also to a BMS or SCADA system. These relays are a dry contact type.

The ARM XL device connects up to a maximum of 10 Exertherm 8-channel Modbus Datacards (80 Exertherm IR or Cable Sensors) and 5 Exertherm MMA units each of which can connect 12 MMD units (60 MCC Drawers). The ARM XL is supplied with a Comms cable for connection to the 8ch Datacard and MMA.

A simple set up, using the pre-configured screens, provides an easy to use graphical interface to indicate the status of all Sensors, as well as providing both local and remote alarms.

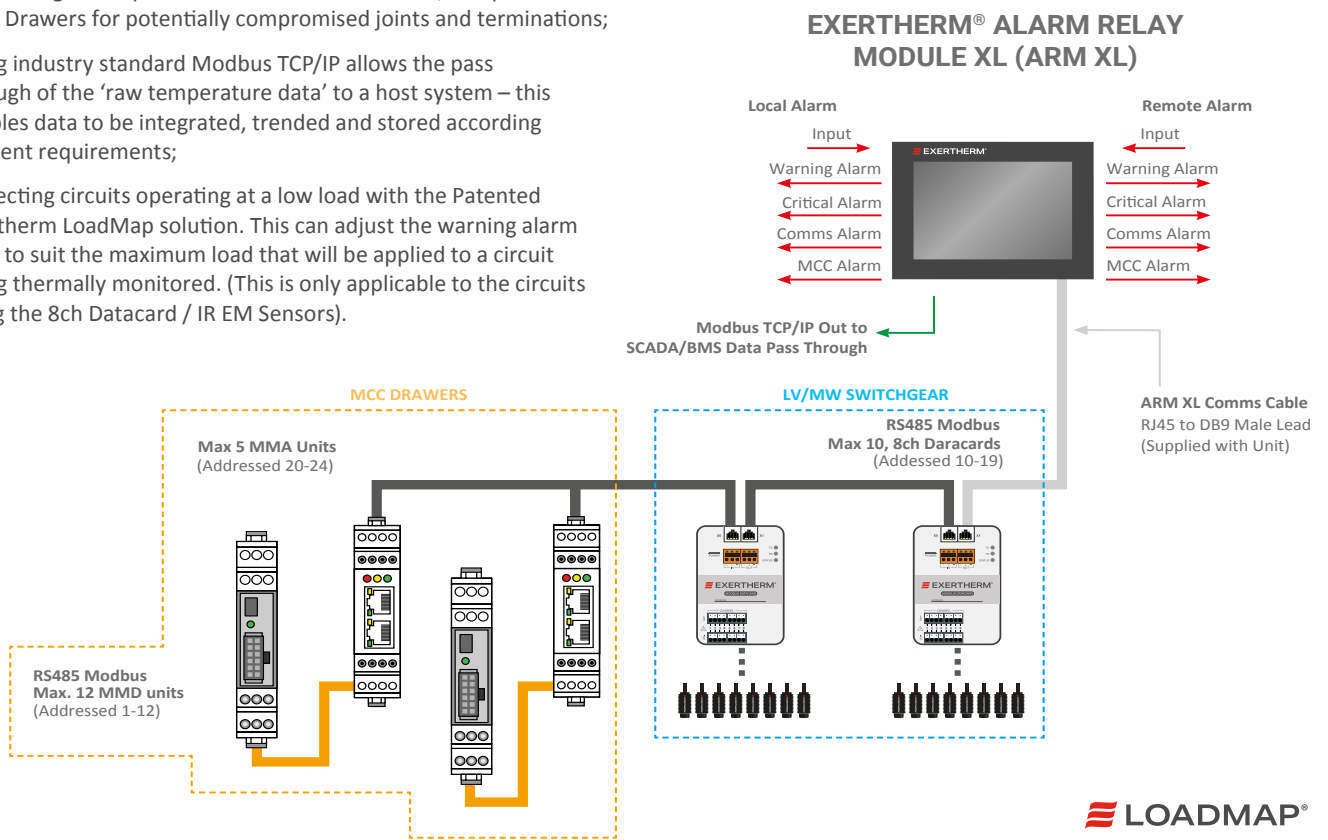

4.3" Touchscreen Display

Features

- ✓ Panel Mounted HMI
- ✓ Plug & Play Solution
- ✓ Pre-configured screens allow simple set-up
- ✓ 2 sets of Relay Alarm Outputs (Local & Remote)
- ✓ Patented LoadMap for load related Warning Alarm threshold (on Exertherm IR Sensors only)
- ✓ Transfer of raw temperature data to host system using Modbus TCP/IP
- ✓ 4 Different Alarms:
 - Warning Alarm
 - Critical Alarm
 - Communication Failure
 - MCC Alarm

MCC 'In-drawer' 24x7 Thermal Monitoring



The Problem

Within the electrical infrastructure the critical Motor Control Centres (MCC) represent a major source of failure.

These failures are caused by a number of different factors including:

- the effect of constant thermal cycling on the joints;
- the high number of site made terminations; and
- weakening of spring-type connectors (jaws);
- the impact of these factors is multiplied by the difficulty in maintaining MCC drawer/buckets.

The Solution: Unique 'in-drawer' 24x7 Thermal Monitoring

As the world leader in Thermal Monitoring of electrical and mechanical infrastructure Exertherm have developed the unique, low cost, patented Exertherm MCC 24x7 Thermal Monitoring Solution. Simple and easy to fit & situated completely within the drawer, this solution provides the ability to permanently thermally monitor the critical connections at the rear of the drawer, via specifically designed measurement techniques for this challenging MCC application, which is globally recognised as a major source of power outages.

MCC 'In-drawer' 24x7 Thermal Monitoring benefits:

- Reduces risk of outages;
- Increases safety;
- No on-going maintenance; and
- Suitable for new-build or retrofit

Exertherm MCC kit/components:

- 1 MCC Datacard
- 2 MCC Sensor Loom
- 3 MCC LED Unit

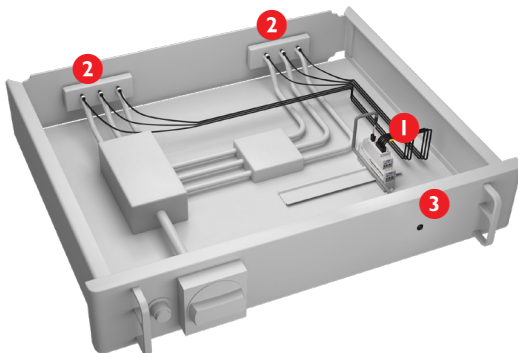

Alarms

Temperature alarms: For the failing termination there are two alarms generated, first the low warning level thermal alarm and should the temperature continue to increase then a high or critical alarm is triggered.

These alarms are visible via a LED status light on the front of the drawer. This provides system status, alarm type and location. Remote alarms are also available through both a volt free relay contact and via Modbus 485.

Phase alarms: The Phase imbalance alarm is generated when, if connected to circuits controlling motors, there is difference in the temperature between the phases. A 10°C differential can identify a phase imbalance which, if not rectified, can half the life of the motor.

MCC Modbus Solution (MMS) Topology

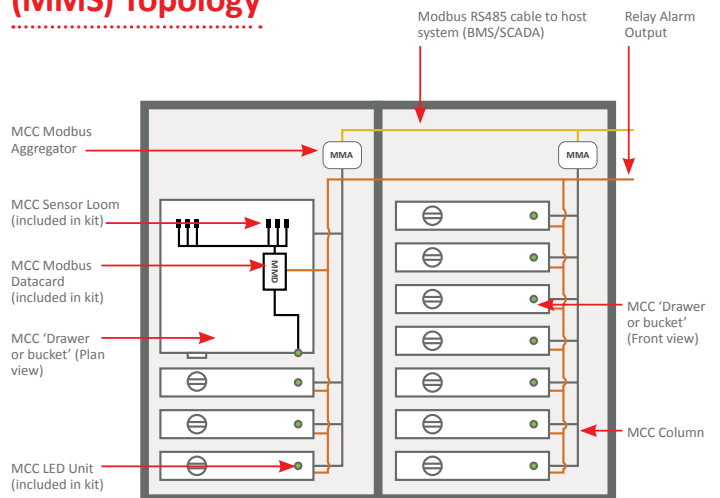

Features

	MCC Modbus Solution (MMS)
Quick and easy fit to any MCC	✓
'In-drawer' solution disconnects and removes with drawer	✓
Supplied in kit form per MCC drawer	✓
Multiple sensor loom lengths to suit different drawer/ bucket sizes	✓
Warning and critical thermal alarms	✓
Phase imbalance alarm for motors	✓
Monitors critical 3 input/3 output drawer connections	✓
Drawer mounted LED provides local visual condition status	✓
Dry contact relay alarm enables remote alarm on client network	✓
Alarms and temperature data available in Modbus protocol for pass through to client system	✓
MCC Modbus Aggregator (MMA) 'gateway' enables network connection of all sensors in MCC column via a single Modbus device	✓